



# AUTOMIZER FULL EJECT

## WHEN A TIP-TO-DUMP TRUCK IS NOT AN OPTION

- 19 yd<sup>3</sup> to 32 yd<sup>3</sup> body sizes available
- Up to 850 lbs/yd<sup>3</sup> compaction
- Single piece body walls for increased strength and seamless appearance
- Best in class Right Hand™ Arm with 12 foot reach and 1000 lb lifting capacity. (95 and 300 gal. available)
- In-line arm design combined with a large 6.5yd<sup>3</sup> hopper for smooth, low dumping and effortless maneuverability
- Tapered body for improved compaction and easy unloading
- Durascope nitrated packer & ejector cylinder with shaver
- Multiplex electrical system with Onboard diagnostic tools for easy troubleshooting
- Fully integrated Labrie CNG systems - roof, tailgate and back of cab mount - 50 to 100 DGE available
- Packer T-track guide system extends packer and wear component life

### Body Specifications

Body Trough	3/16" AR450 175,000psi
Body Trough wear plates	1/4" AR500 190,000psi
Body Floor	3/16" 100QT 100,000psi
Body Floor wear plates	1/4" AR500 190,000psi
Body Sides (lower)	3/16" 100QT 100,000psi
Body Roof	12ga A1011 80,000psi
Tailgate	12ga A1011 80,000psi

### Hopper Specifications

Hopper Size (yd <sup>3</sup> )	6.5
Hopper Trough	3/16" AR450 175,000psi
Hopper Trough wear plates	1/4" AR500 190,000psi
Hopper Floor	3/16" 100QT 100,000psi
Hopper Floor wear plates	1/4" AR500 190,000psi
Hopper Sides (lower)	3/16" 100QT 100,000psi

### Hydraulic Specifications

Pump Make & Model	Dual Vane
Pump Capacity	BODY: 24.5 gpm@700 rpm ARM: 16.3 gpm@700 rpm
Max. Operating Pressure	2,500 psi
Oil Reservoir	84 gal

### Arm Specifications

Arm Lift Capacity	1,000 lbs
Arm Reach	144"
Swing out	36"
Arm Controls	Proportional joystick, electric over hydraulic

### Packer Specifications

Compaction ratio (lbs/yd <sup>3</sup> )	850
Packer Panel Face Plate	1/4" 100QT 100,000psi
Packer Width	63in
Packer Height	24in
Packer Stroke	52in

Note: Specifications subject to change without notice





# AUTOMIZER FULL EJECT

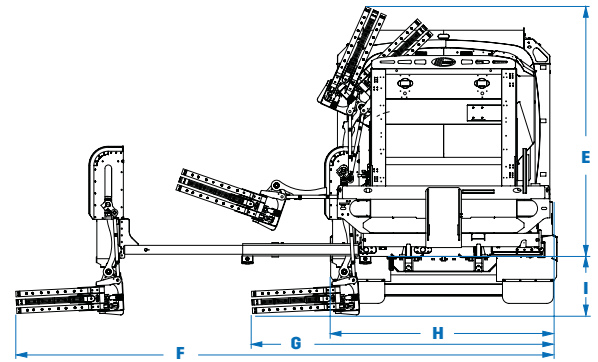
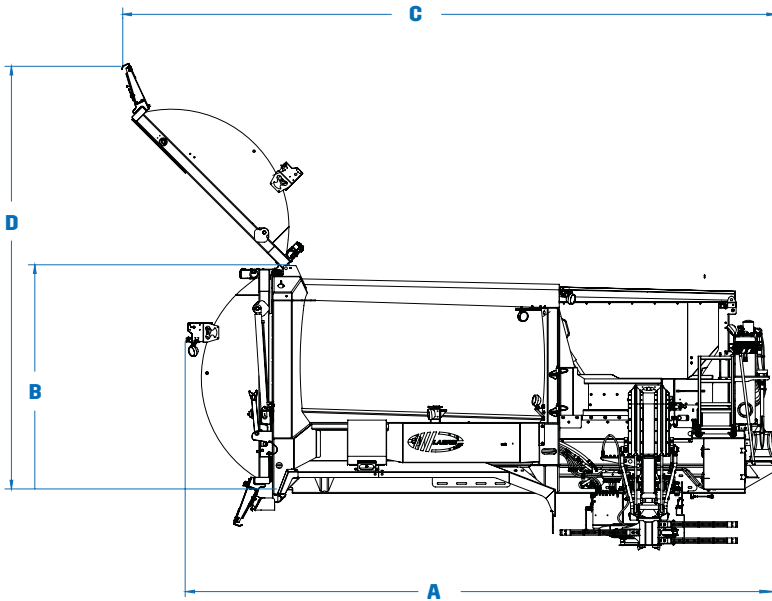

Body Dimensions	19yd <sup>3</sup> (19+0)	21yd <sup>3</sup> (19+2)	23yd <sup>3</sup> (19+4)	25yd <sup>3</sup> (19+6)	26yd <sup>3</sup> (26+0)	28yd <sup>3</sup> (26+2)	30yd <sup>3</sup> (26+4)	32yd <sup>3</sup> (26+6)
A. Overall Length, Tailgate Closed (in.)	254	260	273	288	294	300	313	328
Overall Width (in.)	102	102	102	102	102	102	102	102
B. Overall Height Above Frame, Tailgate Closed (in.)	106	106	106	106	106	106	106	106
C. Overall Length, Tailgate Opened (in.)	304	304	304	304	344	344	344	344
D. Overall Height Above Frame, Tailgate Opened (in.)	199	199	199	199	199	199	199	199
E. Overall Height Above Frame When Dumping (in.)	113	113	113	113	113	113	113	113
F. Overall Width, Arm Out, Grabber Closed (in.)	243	243	243	243	243	243	243	243
G. Overall Width, Arm In, Grabber Closed (in.)	137	137	137	137	137	137	137	137
H. Overall Width, Arm In, Grabber Open (in.)	101	101	101	101	101	101	101	101
I. Distance between bottom of Grabber and chassis frame rail (in.)	25	25	25	25	25	25	25	25

## Performance Specifications

Arm In (96" reach)	2.0 sec @ 700 rpm
Arm In (144" reach)	3.0 sec @ 700 rpm
Arm Out (96" reach)	2.2 sec @ 700 rpm
Arm Out (144" reach)	3.3 sec @ 700 rpm
Arm Up	3.0 - 3.6 sec @ 700 rpm
Arm Down	2.5 - 3.0 sec @ 700 rpm

Grabber Open	1.5 - 2.0 sec @ 700 rpm
Grabber Close	1.5 - 2.0 sec @ 700 rpm
Packer complete cycle	16.5 sec @ 1500 rpm
Tailgate Open	21 sec @ 700 rpm
Tailgate Close	26 sec @ 700 rpm
Crusher panel Up	5sec @ 700 rpm
Crusher panel Down	4sec @ 700 rpm



labriepius  
SERVICE & PARTS

DRIVE EXCELLENCE

labrie